

## External Dimensions (mm)

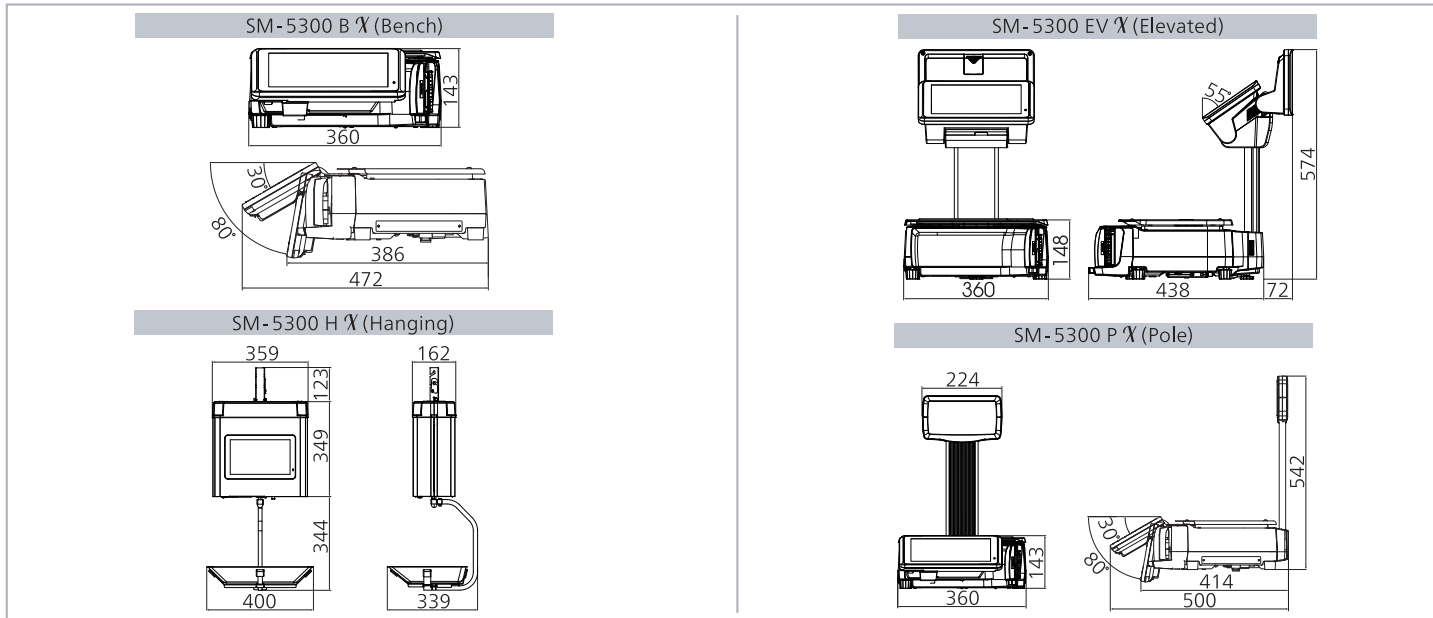

# SM-5300 X

PC Based System Scale Printer

## Specifications

Interval Type	Single Interval	Multi-interval	Multi-Interval kg
Capacity	Max. 30 lb	Max. 30 lb	Max. 15 kg
Scale Interval	e = 0.01lb	e = 0.005/0.01 lb	e = 2/5 g
Weighing Range	0.20-30 lb	0.20-30 lb	40 g-15 kg

Model	SM-5300 B X Bench	SM-5300 P X Pole	SM-5300 EV X Elevated	SM-5300 H X Hanging
Dimension WxDxH(mm)	360 x 472 x 143	360 x 500 x 542	360 x 510 x 574	400 x 339 x 816
Operator Display	10.1" WSVGA with Capacity Touch (1024 x 600)	—	—	—
Customer Display	12.1" TFT SVGA with Touch (800 x 600)	—	—	—
	19" TFT SVGA with Touch (1280 x 1024)	—	—	—
	7" WVGA (800 x 480)	—	—	—
	10.1" WVGA (1024 x 600)	—	—	—
Display Resolution	1 / 3,000, 1 / 6,000 & 1 / 7,500			
Types	Liner		Linerless With Auto-Cutter	
Roll Diameter	125mm (Max)		95mm (Max)	
Label / Receipt	Roll Width 70mm (Max)		61 mm (Max)	
Print Width	71mm (Max)		62mm (Max)	
Printing Speed	Up to 150mm / second*		Up to 150mm / second*	
Print Resolution	300 dpi		300 dpi	
Power Source	AC 100 / 110 or 220 / 230 / 240 Volts (50 / 60 Hz) Auto Switch			
Operating Temperature	-10°C to +40°C			
Humidity	15% to 85% RH			
Standard Interface	Ethernet 10 / 100 Base T, 4 x USB 2.0, RJ11			
Net Weight	10.7 kg	11.7 kg	13.2 kg	14.0 kg
			13.3 kg	17.0 kg
Options	Wireless LAN IEEE 802.11 a / b / g / n / ac, Base Station, e.Label with Hi-Touch, InfoTag, Queue Printer, NF-02, Speed ID & Wristband			
Factory Option	Linerless Printer with Auto-Cutter			

\*To achieve maximum print speed, high sensitivity thermal paper is necessary.

\*\* All the images are used for illustration purpose only.

\*\*\* Console variant is available.



• Specifications are subject to change without prior notice  
 • Meet or exceed OIML Class III requirements



SM-5300 EV X

## DIGI AMERICA Inc.

76 Veronica Ave, Somerset NJ 08873 USA  
 Tel: (732) 828 3633  
 Email: Marketing@us.digi-group.com  
 Web: www.digisystem.com/us



Searching for a New Balance

# SM-5300X designed to Xcite, crafted to Xcel

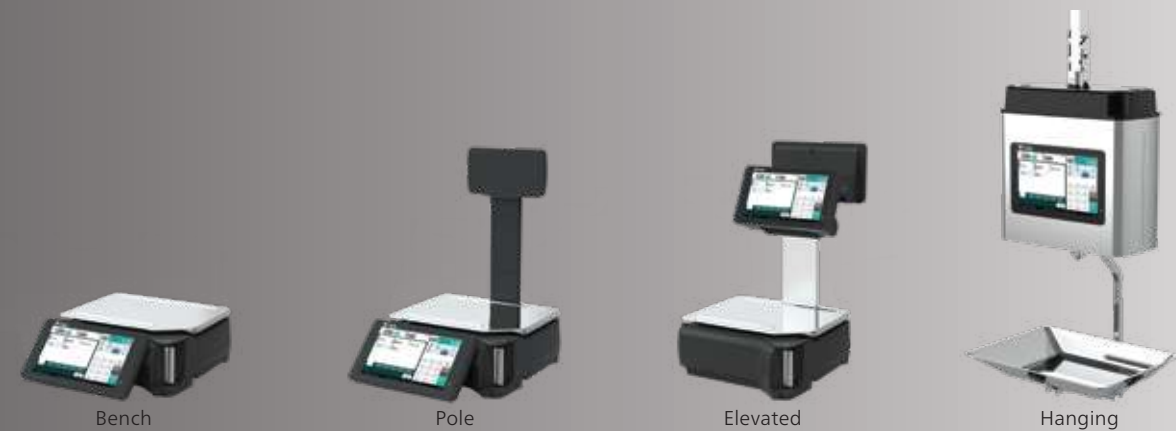

## Xplore new solutions

## Xtensive range



Q management

Maintain social distancing by keeping in-store queues virtual. When combined with the collection system, retailers can offer a contactless pickup experience to ensure the safety of customers and employees.

- Minimizes physical clustering
- Customizable queue and collection ticket
- Optimize waiting time with multi-department queue
- Supports API integration with third-party mobile queue app



speedID

Speed ID taps on RFID technology for a contactless user login to the scale while keeping the scale safe from unauthorised usage. Its touchless nature helps to safeguard the workplace by limiting physical contact amongst operators.

- Available in 2 variants: tag or wristband
- Built-in clerk log report allows contact tracing and reduces shrinkage



Tag Wristband



InfoTag..

InfoTag is an enterprise-grade electronic shelf label that grants pricing automation via wireless updates. Its QR code and NFC - Near Field Communication capabilities make product information readily available to customers via their mobile devices.

- Ensures social distancing with remote price update
- Promote product and speed up order picking with LED flash indicator
- Low temperature variant available for freezer environment



e.Label.. with Hi-Touch

e.Label combines a high definition e-Paper display with the tap-activated Hi-Touch feature to achieve maximum readability and fast PLU call-up. Designed for wet environments, the IP67-certified electronic labels are water-resistant and washable to help retailers maintain high hygiene standards.

- Reduce in-store physical interactions with remote price updates
- Hi-Touch delivers error-free automatic PLU call-up to boost operational efficiency
- Available in 3 sizes (1.54", 2.7", 4.2")

## maXimized value

## Xceptional performance



Waste management

DIGI's waste management solution accurately tracks and measures wastage by capturing its data according to type, quantity or reason and location of disposal.

- Improve procurement planning and profitability by drawing insights from analysis report
- Identify near-expiry products for markdowns

### Next-Generation User Interface

SM-5300X features a new user interface that maximizes screen usage, displaying only the necessary function keys related to each specific mode. When combined with the capacitive touchscreen, navigation is seamless and easy for every user.

- Favorites Tab ★
- Swipe Gestures
- Mode-Specific Function Keys

### Interactive Customer Displays

Native video playback capability offers an additional avenue to showcase promotional contents that can strengthen in-store marketing efforts and boost customer engagement.

- Support dynamic advertisements
- Enable upsell and cross-sell

7" Customer Display for Pole & Bench



10.1" Customer Display for Elevated & Hanging



Linerless Labeling

With no backing paper and twice as many label prints on a single label roll, this sustainable solution helps businesses to maximise inventory space while reducing logistic costs.

- Quick and easy roll replacement
- Flexible label design
- Crisp and appealing label presentation